

**DUAL SERIAL / QUAD ANALOG INPUT NETWORK BRIDGE**

- Very compact design available in DIN Rail and NEMA 4X enclosures.
- Neuron 3150 at 10 MHz and FTT-10A network interface.
- Switching power supply with wide input voltage range of 8 to 32 VDC. Minimizes heat and power consumed under a variety of input voltage conditions. Helpful in battery backed systems.
- 32K Non-volatile memory with unlimited writes. Use as RAM or EEPROM and there is no battery.
- Standard 28-Pin dip memory socket accommodate lower cost flash or OTP ROM for mass production.
- Real-time clock with capacitor backup. Maintains clock for 15-30 days without power.
- Two memory mapped serial ports with a 128 byte transmit and receive buffers reduce firmware overhead.
- Each serial port can be configured for RS232, RS485/RS422 Full Duplex, RS485 Half Duplex, or TTL. Port configuration is under software control and is jumper-less.
- Full RS232 handshake signals (RTS, CTS, DTR, DSR, DCD) on each serial port.
- Transmit and Receive Status LEDs for each of the serial ports.
- All serial port communication lines have 10KV ESD protection and are protected to +/- 25 volts.
- High quality removable terminal blocks on all connections.
- Expansion connector allows additional I/O to be added via I2C bus interface.
- Support for two 0-23 mA analog inputs. Supports self and loop powered devices. The current inputs are reverse voltage protected and current limited to avoid damage under faulty wiring conditions.
- Support for two analog 0-5 Volts inputs. The two voltage inputs can be read individually or differentially. Low noise, 10 PPM, 5.0 volts analog reference is available to drive low current bridge sensors.
- The Analog to Digital converter has 16-bit resolution and a firmware selectable gain of 1, 2, 4 or 8.
- 500+ K bytes of serial flash for data logging.
- Two status LEDs provide quick visual indication of runtime status conditions.
- Extensive development library and demo application available at no charge to help speed up integration and custom application development.

## DESCRIPTION

The Model 2800 is a LonWorks based product that combines many different interfaces into a single very compact unit. It has two high-speed serial ports, four analog inputs, real-time clock, I2C Expansion Bus, and over 500K of serial flash memory. It is designed to allow system developers to quickly create LonWorks serial and analog gateways to existing systems. An extensive function library is supplied to help the development and integration process. It is available in NEMA 4X and DIN Rail mount enclosures.

## DIN Rail Enclosure

The DIN Rail Enclosure allows mounting on a standard 35 mm DIN Rail. Please see the diagram below. Note, you must remove the top cover with a small screwdriver to access the Service Switch.

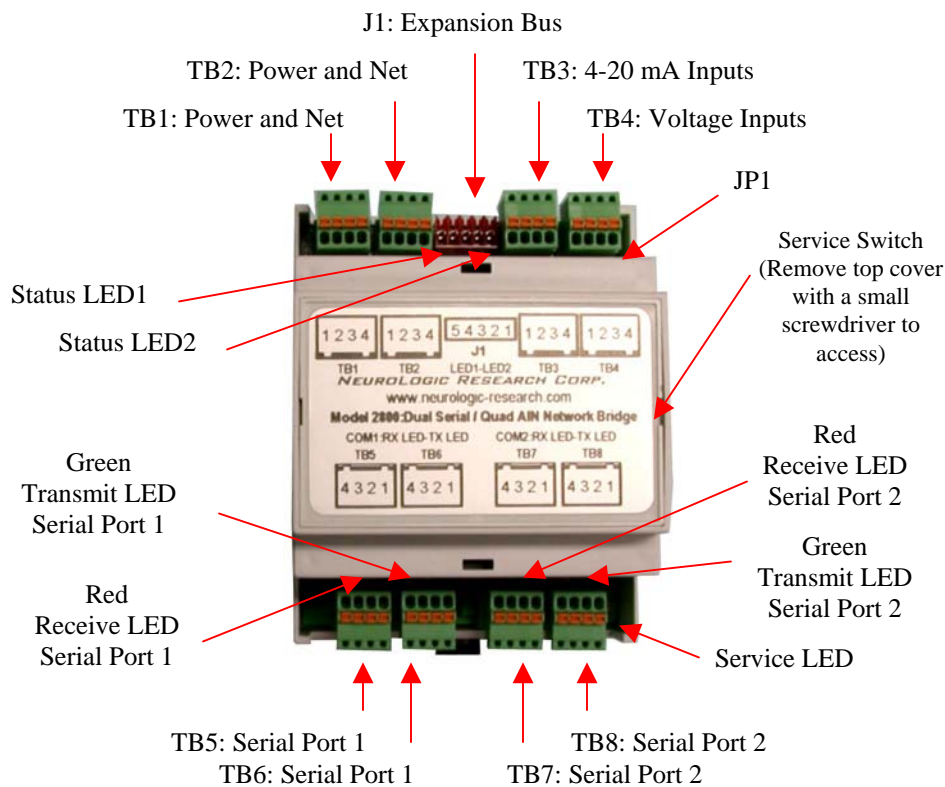

## NEMA 4X Enclosure

A diagram and layout of the NEMA 4X Enclosure option is shown below. The enclosure can be wall or panel mounted and is appropriate for outdoor environments. To do so, remove the cover. See picture below. Use a #6 screw and drop into mounting holes shown below. Note, mounting holes do not violate the enclosure seal. **Please do not drill holes into the bottom of the enclosure. This voids the NEMA 4X rating.**

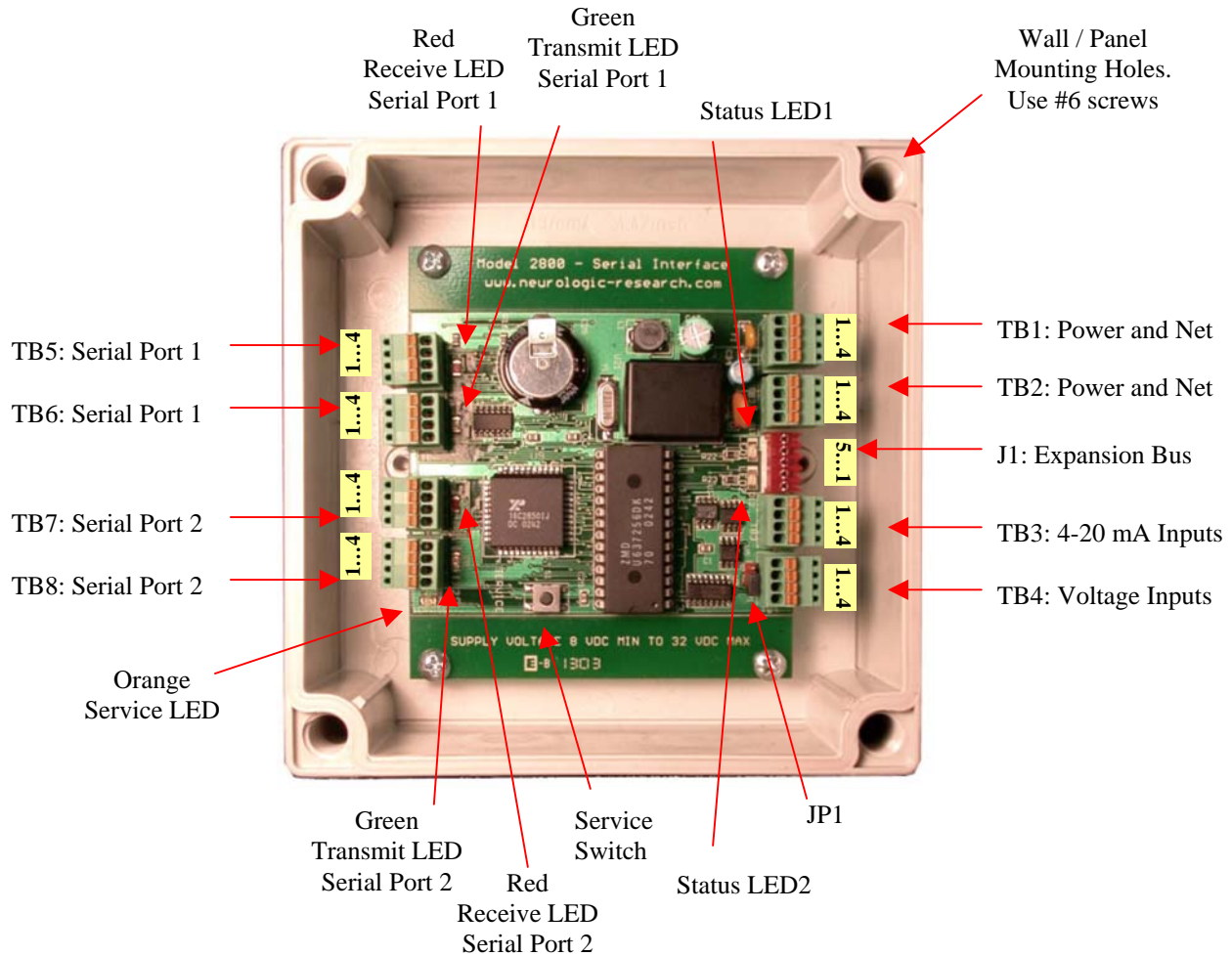

The sides of the enclosure have knockouts of different diameters. Please see the diagram below. The enclosure is shipped with all knockouts intact. This allows the customer to use the one most appropriate for his/her installation. Please note the 20 mm knockout should work well with 1/2" NPT conduit hubs as well as cable glands. The larger knockouts of 32/20 mm are located at top and bottom sides in the orientation shown above. **For best results, conduit entries should be attached to the bottom side.** This prevents condensation in the conduit from draining into the enclosure.

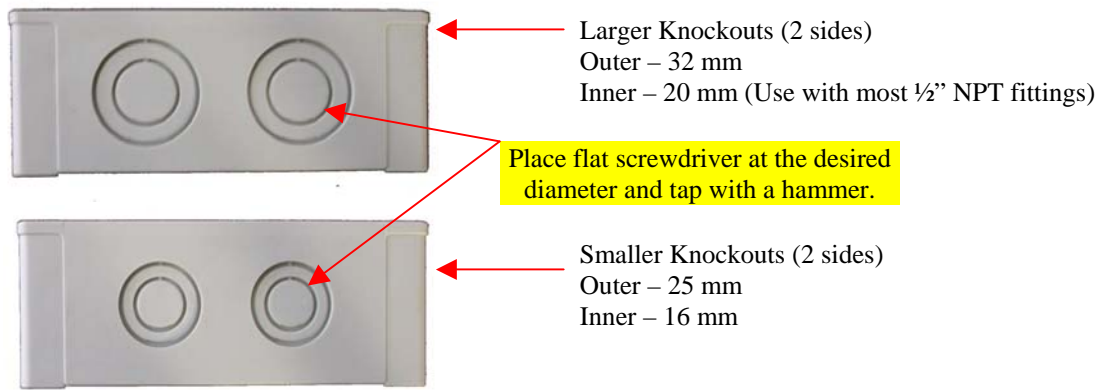

**Input Power and Network Interface**

The Model 2800 has an efficient switching power supply that operates from 8 to 32 Volts DC and typically draws less than 0.75 watts. Additionally, it can supply up to 100 mA to external interfaces via the J1 connector. While supplying the full 100 mA to external devices the unit draws less than 1.5 watts. Input power is reverse voltage protected.

The network interface is Echelon’s FTT-10 Free Topology Transceiver. The interface includes DC blocking capacitors for compatibility with Link Power Transceivers. The network connection is not sensitive to polarity. Please note, the Model 2800 does not include any network termination and it must be added externally.

Power and network are connected via terminal block TB1 or TB2. The two connectors are identical to allow for daisy chaining.

TERMINAL BLOCK	FUNCTION
TB1	Power and Network Connection. 1: NetA 2: NetB 3: Vin+ = Input DC voltage 8-32 VDC 4: Vin- = 0 reference of Input DC voltage or Digital Ground
TB2	Same as TB1, use to daisy chain to next network node

**Status LEDs**

As shown in the diagrams above, there are two green status LEDs. The LEDs are tied to the frequency output lines of the Neuron. This allows different flash rates to be displayed with minimal firmware overhead. The flash rates can be used to indicate different operating status conditions.

**Serial Interface**

The Model 2800 uses a high performance dual serial port controller. It contains a 128 byte transmit and a 128 byte receive buffer for each port. The Controller is memory mapped into the Neuron’s address space for quick access to its registers.

Each of the serial ports can be configured for RS232, half-duplex RS485, full-duplex RS485/422, or TTL signal levels. In RS232 mode, RTS, DTR, CTS, DSR, and DCD signals are also available. Note, RI is not available. The type of interface controlled by firmware and there are no jumpers to set. In half duplex

RS485 mode, the on-board Controller automatically turns off the transmit buffers after data is transmitted. All serial communication lines have +/- 25 volts protection as well as 10KV ESD protection. **Please note, in RS485 and RS422 modes, the user must install external termination resistor for proper operation.** Typically an RS485 bus topology is terminated at both ends using 120-Ohm resistors.

The supplied library contains functions that setup the serial interface and allow reading and writing data from and to it. For most applications, the user will not have to understand the underlying structure of the Controller.

TERMINAL BLOCK	FUNCTION
TB5	<b>Serial Port 1 I/O Connector A</b> 1: Ground, same as TB1-4 2: 232 DTR Out 3: 232 DSR In 4: 232 DCD In
TB6	<b>Serial Port 1 I/O Connector B</b> 1: 232 RX In / 485 RX - 2: 232 CTS In / TTL RX In / 485 RX + 3: 232 TX Out / 485 TX - 4: 232 RTS Out / TTL TX Out / 485 TX + Note - In 485 Half Duplex mode, 485 TX and RX signal pairs are internally connected together. Either +/- Pairs can be used for Half Duplex communication.
TB7	<b>Serial Port 2 I/O Connector A</b> Same as TB5
TB8	<b>Serial Port 2 I/O Connector B</b> Same as TB 6

### Analog Inputs

The Model 2800 includes a high-resolution differential Analog to Digital converter. The A/D has a differential resolution of 16 bits (+/- 15 bits). The maximum resolution for ground-referenced signals is 15 bits. The voltage reference is 5 volts with a 10-ppm temperature drift per degrees C. The A/D has a software programmable input gain stage of 1, 2, 4 or 8.

The A/D allows a tradeoff of resolution versus speed when needed. The update rate is a nominal 8 samples per second to achieve the maximum resolution. However, an update as high as 128 samples per second is available if a resolution of 12 bits (+/- 11 bits) is acceptable.

TERMINAL BLOCK	FUNCTION
TB3	1: Vin+, Same as TB1-3 2: Vin+, same as TB1-3 3: Iin1, 4-20 mA input 1 4: Iin2, 4-20 mA input 2
TB4	1: Vref, 5.0V analog reference voltage. Low noise, 5 mA max 2: Vin1, 0-5.0 volts analog input voltage 1 3: Vin2, 0-5.0 volts analog input voltage 2 4: Agnd, Analog Ground

## Current Inputs

There are two current input channels that can be connected via the TB3 terminal block. The inputs are over-current protected by limiting the current at about 23 mA. The two current inputs are appropriate for interfacing to 4 to 20 mA devices. Input current in the range of 0 to 23 mA can be measured.

Loop powered 4-20 mA devices as well as self-powered 4-20 mA devices can be connected to the Model 2800. Loop powered 4-20 mA devices connect using only two wires and are powered by the loop. Loop powered devices are normally simple sensors such as pressure or temperature that can operate on currents down to 4 mA. Self-powered devices normally require higher currents and usually require a three-wire interface: Power, Ground, and Current Output.

To connect a loop-powered 4-20 mA device to the first Model 2800 current input, wire the '+' terminal of the external device to the TB3-1 and the '-' terminal to the TB3-3. The second device would connect to TB3-2 and TB3-4.

To connect a self-powered device, connect the analog ground of the Model 2800, TB4-4, to the power supply common of the device. Second, connect the current output of the device to the Model 2800's current input at either TB3-3 or TB3-4.

To get the maximum resolution while reading a 4-20 mA device, use the A/D with a gain of 2. See the 2800LIB documentation for more detail.

## Voltage Inputs

The Model 2800 has two voltage inputs. They have a range of 0 to 5.0 volts and can be read differentially or individually. Voltage inputs are connected via TB4. Note that there is a separate Analog Ground. For maximum accuracy, connect the Analog Ground to voltage inputs and not the main power supply ground. The 5.0 Voltage Reference is also available at TB4-1 to power bridge sensors. It should not be used to supply more than 5.0 mA of current.

Please note, that while the differential voltage input range is +/- 5.0 volts, the actual input voltages at TB4-2 and TB4-3 have to be positive with respect to Analog Ground at TB4-4.

The input impedance of the A/D is 2.4 M Ohm/Gain can be low. It should be taken into consideration if the output impedance of the input source is high.

**The jumper at JP1 should be off when making voltage measurement.** When the jumper is connected it connects the 5.0 Voltage Reference through a 10K Ohm 0.1%, 10-ppm Reference Resistor, to the V1 input at TB4-2. This may be used for make resistance measurements. This function is reserved for future use and characterization.

## Real Time Clock / Calendar

The Model 2800 includes a Real Time Clock, RTC, which uses a large capacitor for backup. The RTC will maintain time in the absence of power for two to four weeks. Neuron C functions are provided to read and write the time, date, and day of week.

## Expansion Port

The Model 2800 has an I2C compatible expansion bus at connector/header J1. I2C is a serial bus developed by Phillips that allows two-way communication using only two wires and a ground. The two wires are made up of a data and clock line. Devices on the I2C bus are addressable and share the bus. There can be many slave devices attached to a master device. The Model 2800 is the master on the expansion bus and would communicate with slave I2C devices.

This feature allows additional low cost hardware interfaces to be developed. Ideally, each additional interface will have two identical connectors similar to J1. This would allow daisy chaining multiple devices to a single Model 2800.

The J1 connector makes available not only the I2C data and clock signals but also the input voltage applied to TB1/TB2 connectors as well as a regulated +5 volts supply. The 5 Volts outputs can supply up 100 mA to external interfaces.

The Model 2800 uses several I2C peripherals. Please note that no distinction is made between local and remote I2C peripherals. **External I2C interfaces must not use the following addresses: 0x57, 0x48 and 0x6F.**

J1 is a 5-pin connector that uses an AMP MTA100 Plug/Header. The part number for the AMP MTA100 Header is 640454-5. The part number for the AMP MTA100 Plug is 643813-5 or 640440-5. The Plug is an insulation displacement type for use with 22 AWG wire. An AMP MTA100 tool is required to push the wires onto the connector. It is a two-piece tool with AMP part numbers 58074-1 and 58246-1

CONNECTOR	FUNCTION
J1	I/O Expansion Header 1: Ground 2: I2C Data 3: I2C Clock 4: Vcc = 5.0 Volts. Digital Voltage source, 100 mA maximum. 5: Vin+, same as TB1-3

***Flash Memory***

The Model 2800 has 540,672 bytes of serial flash memory. It can be used for data logging, numerical lookup tables, or ASCII string storage for large user interface application.

The flash memory device is organized in an array of 2048 pages. Each page consists of 264 bytes. The flash memory chip has internal RAM buffers and requires very little memory resources from the Neuron’s main memory. The supplied library functions allow a page of memory to be read, written and erased.

***Development Library***

An extensive development library is available at no charge. Please see the 2800LIB.PDF file for complete documentation. The library is very compact, about 2.5K, and provides a simple and consistent read/write interface to each of the Model 2800’s hardware subsystems.

***Demo Application***

A 2800DEMO application is available. It allows most of the Model 2800’s functions to be exercised from the LonWorks network interface and without writing any application code. Please see the 2800LIB.PDF file for full documentation. The 2800DEMO application can be downloaded via the network using a network management tool such as Echelon’s LonMaker.

## GENERAL SPECIFICATION

### General

CPU	3150 Neuron @ 10 MHz
Operating Temperature	-40 – 85° C
Operating Humidity	0-95% Relative Humidity non-condensing
Input Power	8 to 32 VDC
Input Power Protection	Input power is fused and transient voltage protected. (Fuses do not need to be replaced)
Current Consumption	0.75 watts typical without any power supplied to external current input devices or external devices via J1 connector.
Regulated 5.0 Volts DC at J1 Connector	5.0 Volts DC at 100 mA maximum. (Note, allow for additional 0.75 watts into TB1/TB2)
Network Transceiver Type	Echelon FTT-10A transceiver at 78 kbps. DC blocking capacitors for LPT10 network.
Input Power and Network Wiring	Removable terminal blocks. Accepts up to 20 GA wire. Input power is reverse voltage protected. Network wiring is polarity insensitive.
Main Memory	32K NVRAM that does not require a battery. Unlimited writes.
Flash Memory	540,672 bytes organized in 2048 pages each being 264 byte long
Real-Time Clock	Capacitor backed Maintains date and time two to four weeks without power.

### Analog to Digital Converter

Voltage Reference	5.0 +/- 0.005 volts
Voltage Reference Drift	10 ppm typical / 15 ppm maximum per degrees C
Voltage Reference Noise	3 uV peak to peak maximum
Input Impedance	2.4 M Ohm / PGA. Example: 2.4 M Ohm at Gain of 1 and 1.2 M Ohm at gain of 2.
Differential Resolution	+/- 15 bits
Single Ended Resolution	15 bits
Gain	1, 2, 4, or 8
Non-Linearity	0.003% Typical, 0.0125% Maximum of Full Scale Range = (2*5.0/Gain)
Offset Error	+/- 2.5/Gain mV Typical, +/- 5mV/Gain Maximum
Offset Drift	Gain 1: 1.5 Typical, 8 Maximum uV per degrees C Gain 2: 1.0 Typical, 4 Maximum uV per degrees C Gain 4: 0.7 Typical, 2 Maximum uV per degrees C Gain 8: 0.6 Typical, 2 Maximum uV per degrees C
Gain Error	0.01% Typical, 0.1% Maximum
Gain Error Drift	2 ppm per degree C Typical

### Voltage Inputs

Inputs	2 - Single Ended 1 - Differential
Input Range	0 to 5.0 volts relative to Analog Ground +/- 5.0 volts differentially
Resolution	5.0 Volts / (Gain * 32767) Relative to Analog Ground Example: 153 uV at a gain of 1.
Input Protection	Protected to 8 volts continuously

### Current Inputs

Inputs	2
Sense Resistor	100 Ohm +/- 0.1%
Sense Resistor Drift	10 ppm per degrees C
Input Range	0 to 23 mA
Resolution	50 mA / (Gain*32767) Note: At gain of 2, resolution is 0.76 uA
Input Protection	Current Limited at about 23.5 mA 32 volts continuously

**Serial Communication**

Serial Ports	2
Serial Ports Buffers	128 byte transmit and 128 byte receive buffers on each port
Serial Port Interfaces	RS232, RS485 half-duplex, RS485/RS422 full-duplex, TTL
Serial Port Protection	+/- 25 volts as well as ESD protection of +/- 10KV

**Dimension and Materials**

DIN Rail Enclosure's external Dimension	71 mm (2.8") W x 90 mm (3.54") L x 58 mm (2.28") H
DIN Rail Enclosure's Material	Grey frame retardant Noryl UL94
NEMA 4 Enclosure's external Dimension	130 mm (5.12") W x 130 mm (5.12") L x 60 mm (2.36") H
NEMA 4 Enclosure's Material	Grey polycarbonate with translucent polycarbonate cover. Flame retardant UL94

**ORDERING INFORMATION**

<b>2800</b>	<b>Model 2800 Dual Serial / Quad Analog Input Network Bridge</b>
-------------	--

Code	Enclosure / Housing Options
-0	NEMA 4X
-1	DIN-Rail Mount

Code	Network Communications Option
-0	TP/FTT-10A - LonWorks

<b>2800</b>	<b>-1</b>	<b>-0</b>	<b>Model 2800 with LonWorks FTT-10A transceiver in DIN-Rail housing</b>
-------------	-----------	-----------	---

Echelon, LON, LONWORKS, Neuron, 3120, 3150, and LONMARK are trademarks of Echelon Corporation.