

NEUROLOGIC RESEARCH CORPORATION

1742 W. Katella, Ste 9, Orange, CA 92867
(714)997-4255 Voice (714)997-5884 Fax

MODEL 1450 4-20 mA INPUT MICRO BRIDGE OVERVIEW

An outline of the Model 1450 Micro Bridge is shown below. It is 1.5" L X 1.5" W X 0.5" D. It is shown below in actual size.

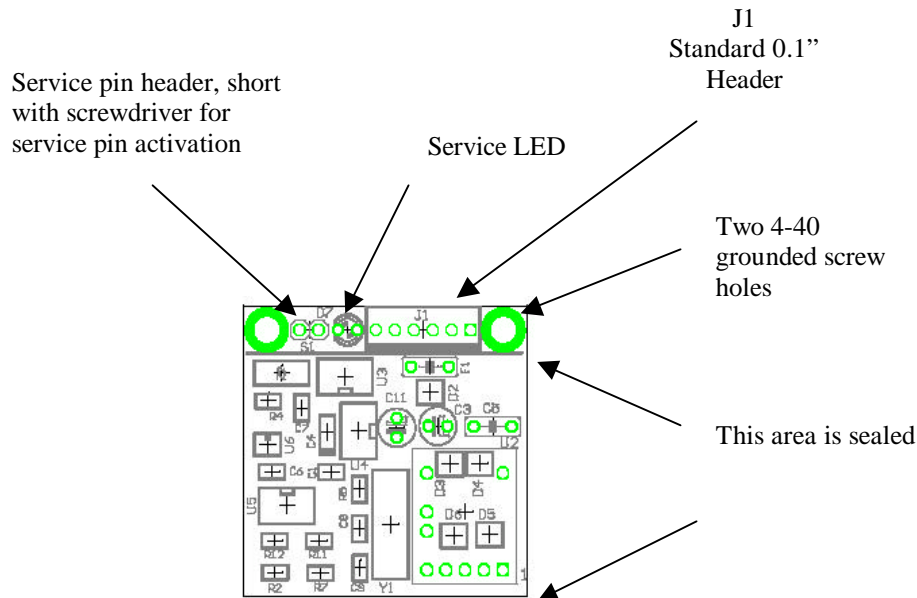

Features

- Low cost
- Instantly integrate any standard 4-20 mA sensor into the LONWORKS[®] digital network.
- Supports loop and self powered devices.
- Digitally calibrated for accuracy and custom inputs.
- Very stable 15 ppm voltage reference.
- Input can be rescaled anywhere between 0-23 mA with a resolution of 0.8 uA and accuracy of 10 uA.
- Very compact 1.5" L x 1.5" W x 0.5" H electronics are environmentally sealed. Two 4-40, grounded, screw holes allows the unit to be easily mounted.
- J1 Header allows easy integration and can be supplied with mating connector attached to flying leads.
- Operates from a wide power supply range of 10- 32 VDC. Input power is reverse voltage protected, current limited and has transient voltage suppression.
- Operates over a wide temperature range of -40 to 85 C.
- All data is available using Standard Network Variable Types (SNVT)
- On-board service pin header and LED.
- FTT-10 transceiver with DC blocking capacitor

NEUROLOGIC RESEARCH CORPORATION

1742 W. Katella, Ste 9, Orange, CA 92867
(714)997-4255 Voice (714)997-5884 Fax

J1 Header Wiring Connections

Pin	Description
1	FTT-10 Network A
2	FTT-10 Network B
3	Input DC Power + (J1-3 and J1-4 are shorted)
4	Input DC Power + (J1-3 and J1-4 are shorted)
5	Input DC Power - / Ground
6	Current Input

Typical Wiring Diagrams

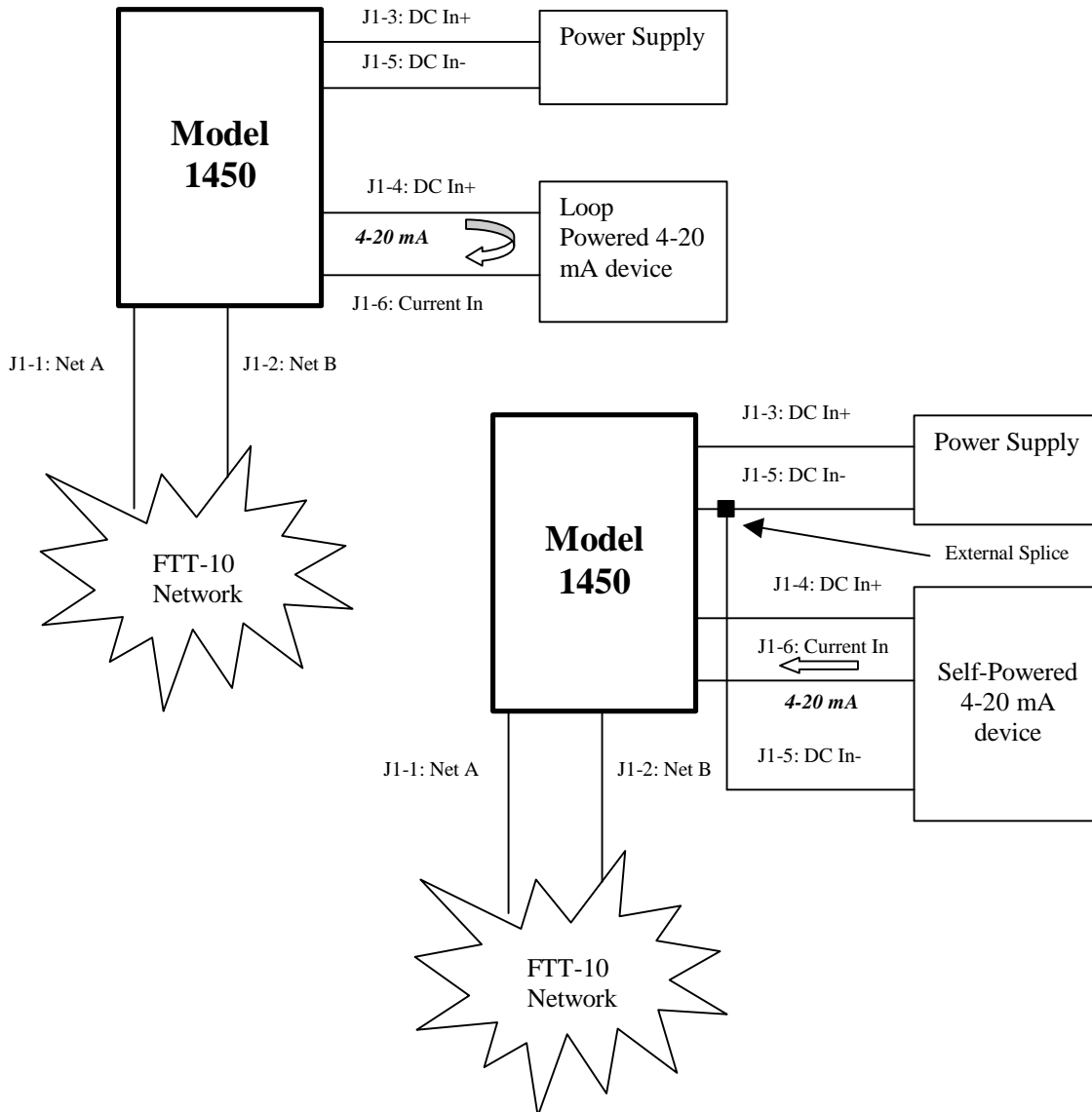

NEUROLOGIC RESEARCH CORPORATION

1742 W. Katella, Ste 9, Orange, CA 92867
(714)997-4255 Voice (714)997-5884 Fax

Output Network Variables

Network Variable	Format	Description
nvoAI	SNVT_lev_percent	Input current. Factory Calibration is 0% = 4 mA, 100%=20 mA but it can be re-scaled using nviCalibrate and nviCalibVal input network variables. Returnes +163.83% on input fault condition
nvoDI	SNVT_lev_discrete	Input current interpreted as a discrete. Return ST_OFF if input is below nciDIHigh and ST_ON if input is above nciDIHigh. ST_NUL in input fault condition

Input Network Variables

Network Variable	Format	Description
NviCalibrate	Unsigned int	<ul style="list-style-type: none">- 00 – Zero Cmd. The applied current input signal corresponds to 0%.- 01 – Span Cmd. The applied current input signal corresponds to 100%.- 02 – Calibrate Value #1. The applied current input signal corresponds to lower value, which is nviCalibVal.- 03 – Calibrate Value #2. The applied current input signal corresponds to upper value, which is in nviCalibVal.- 15 – Reset calibration to factory defaults
NviCalibVal	SNVT_lev_percent	See nviCalibrate for description. Used with Commands 2 and 3.

Configuration Network Variables

Network Variable	Format	Description
NciAIOffset	SNVT_lev_percent	Offset to be added to nvoAI before sent onto the network
NciMinDelta	SNVT_lev_percent	Minimum change required before a network update
NciMinSendT	SNVT_time_sec	Minimum elapsed time before a network update is sent
NciMaxSendT	SNVT_time_sec	Maximum elapsed time before a network update is sent