

**AC VOLTAGE DETECTOR**

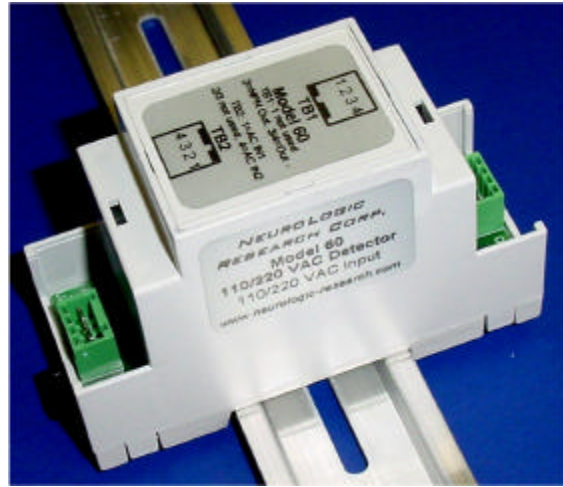

- Transformer-isolated 80 – 265 AC voltage detector.
- Sealed transformer with 4000 volts isolation
- Output is a standard NPN type that is filtered and exhibits no bounce.
- Low voltage electronics are transient voltage protected.
- On-board signal processing circuit is powered by AC input.
- Local LED provides visual indication
- Available in NEMA 4 and DIN-Rail mount enclosures.
- Operates over wide input temperature range of –40 to 85°C

**DESCRIPTION**

The Model 60 is a rugged, transformer isolated, AC voltage detector. It is available in a NEMA 4 or DIN-Rail enclosure. It is capable of detecting a wide input voltage range of 80 to 265 VAC. The output is a standard NPN transistor type. Please see the block diagram below.

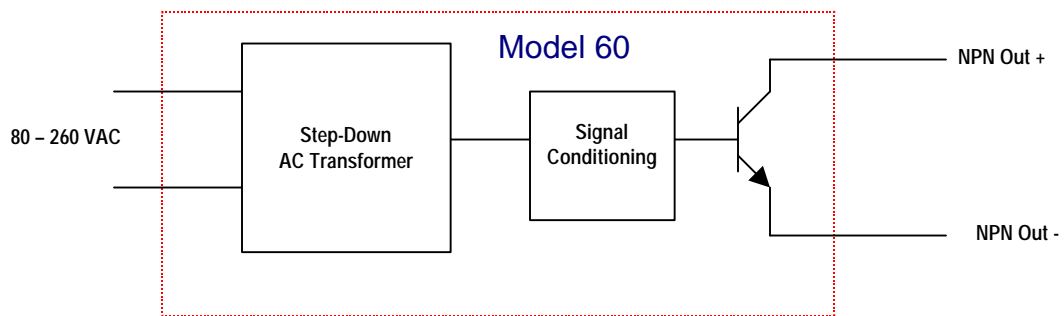

The transformer provides 4000 volts of isolation and steps down the high voltage AC input to a much lower voltage that can be used by the electronics. The electronics draw power from the low voltage AC signal, condition it and drive the NPN output. The NPN output is activated and the on-board LED is illuminated to indicate the presence of the AC input signal. The AC signal is filtered to provide a clean bounce-free output.

## MODEL 60

The Model 60 can be connected to the *NeuroLogic Research Corp.* Model 2200 to count and measure the frequency of AC detections and transmit the information on a LonWorks network. The Model 60 can be effectively used to detect AC presence in relays, solenoid, motors, actuators or any other AC operated device. The NPN output can then be used to count the occurrences, initiate an alarm or be used as part of a control strategy.

### WIRING AND INSTALLATION

Installing the Model 60 involves the following steps:

- Mounting the enclosure
- Connecting the AC Voltage
- Connecting the NPN output

#### Mounting the Enclosure

The Model 60 is available in a DIN-Rail and NEMA 4 enclosure. The DIN-Rail enclosure is mounted on a standard 35 mm DIN-Rail.

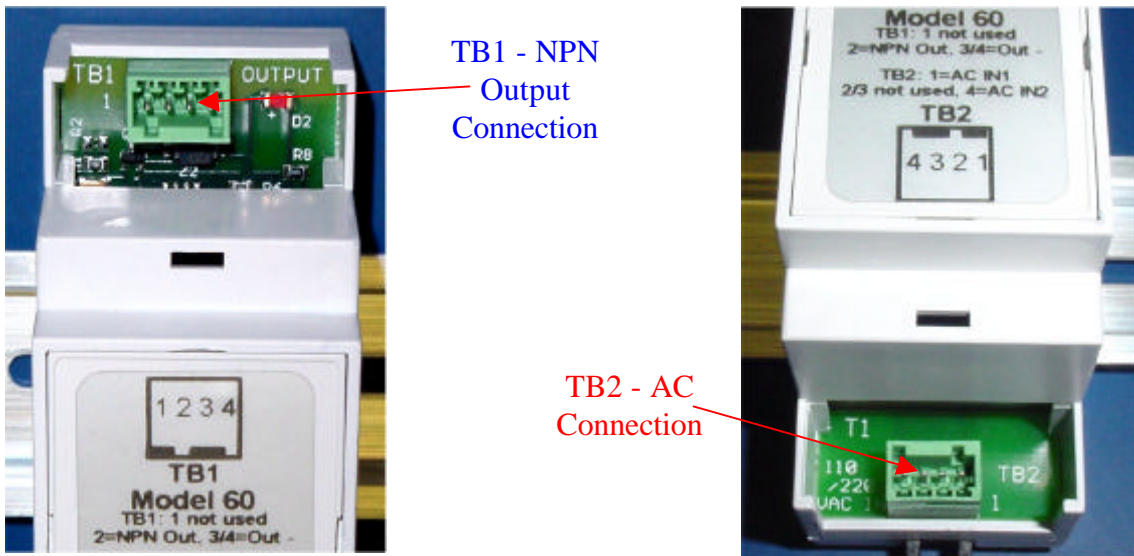

The NEMA 4 enclosure can be wall mounted or panel mounted and is appropriate for outdoor environments. To do so, remove the cover. See picture below. Use a #6 screw and drop into mounting holes shown below. Note that mounting holes do not violate the enclosure seal.

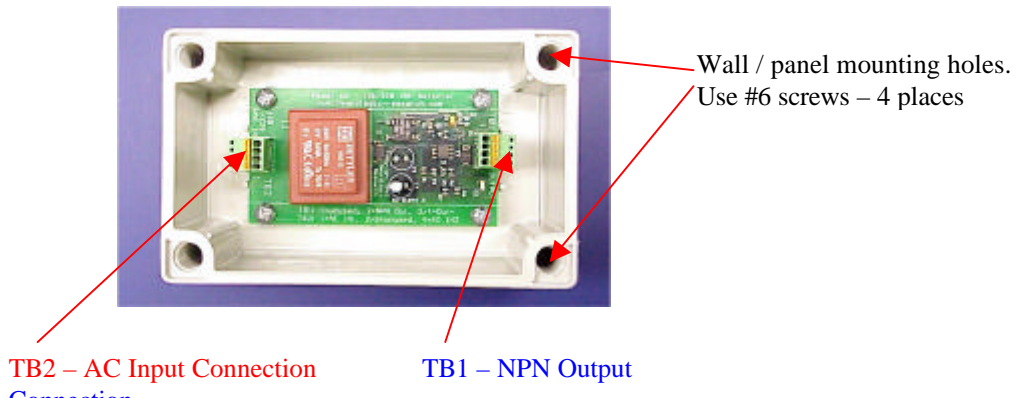

# MODEL 60

# MODEL 60

## Connecting the AC Input

The high voltage AC Input connects to a four position terminal block labeled TB2. Please note, only position 1 and 4 are used. The terminals are not polarity sensitive.

**WARNING**  
Please wire the AC input **before** applying electrical power.  
Failure to do so may result in electrical shock.

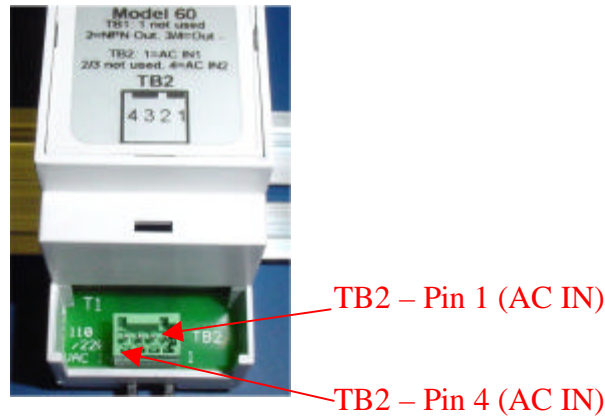

## Connecting the NPN Output

The NPN output can switch a voltage up to 32 volts and it is transient voltage protected. The maximum current that can be switched is 75 mA. Normally the NPN Out- is wired to the ground of the sensing electronics. The NPN Out+ is often wired to a remote voltage source through a pull-up resistor. Care must be used to insure that the 75 mA capacity is not exceeded. That is, if a 24 volts voltage source is used, a minimum pull-up resistor that can be used is 320 Ohms. For 12 volts, a minimum pull-up resistor is 160 Ohms. Since the Model 60 includes transient voltage protection on the NPN output, it can be used to drive a relay coil without damage. The relay coil resistance must not draw more than 75 mA at the rated voltage.

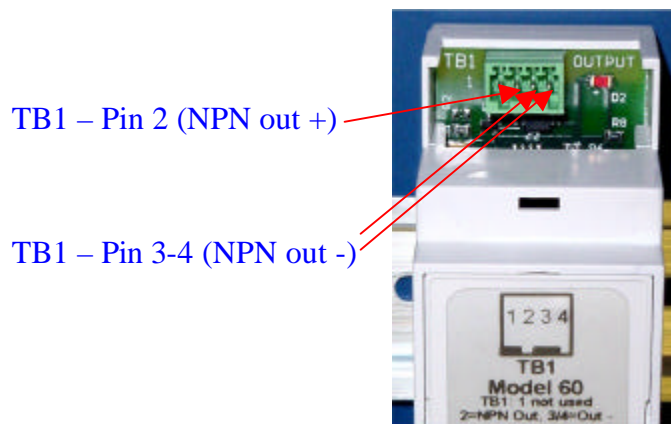

## GENERAL SPECIFICATIONS

### Electronics

Operating Environment	-40 to 85C, 0-95% RH non-condensing
NPN Output	32 VDC maximum NPN collector voltage at 75 mA maximum
AC Input	80 to 260 VAC input range at 50/60 Hz
AC Transformer	UL / VDE rated Sealed, 4000 VAC isolation
Input Power Protection	Electronics are transient voltage protected.
Terminal Blocks	Screw-less, removable terminal blocks. Accepts up to 20 GA wire.

### Dimension and Materials

DIN Rail Enclosure's external Dimension	36 mm (1.8") W x 90 mm (3.54") L x 58 mm (2.28") H
DIN Rail Enclosure's Material	Grey frame retardant Noryl UL94
NEMA 4 Enclosure's external Dimension	80 mm (3.15") W x 130 mm (5.12") L x 60 mm (2.36") H
NEMA 4 Enclosure's Material	Grey polycarbonate with translucent polycarbonate cover. Frame retardant UL94

## ORDERING INFORMATION

<b>0060</b>	<b>Model 60 AC Input Detector</b>
-------------	-----------------------------------

Code	AC Input Range
-1	80 to 265 V AC

Code	Enclosure Options
-0	NEMA 4X with ½ NPT conduit hub
-1	DIN-Rail Mount

<b>0060</b>	<b>-1</b>	<b>-0</b>	<b>Model 60 Input Detector, 80 to 265 V AC input range, with ½ NPT conduit hub</b>
-------------	-----------	-----------	--

## ASSOCIATE PRODUCTS

Model 2200 2-Channel Pulse Count Input Network Node

Model 65 Sensor Logic Block